



Lenovo Packaging Specification 41A0614

General Pallet Unitization Requirements *"Best of Breed"*

REVISION HISTORY

Rev	Revision Description	Date
A0	Creation	23-Sep-09
A1	Update Pallet list & Palletization Material Specifications	25-Nov-27



Table of Contents

1.0 Introduction	4
1.1 Abstract	4
1.2 Purpose	4
1.3 Compliance	4
1.4 Scope	4
2.0 Acceptable Unitization & Securement Methods	5
2.1 Method 1 – Roping Technique and 2-way Banding	5
2.2 Method 2 – Hand Stretch-Wrapping and 4-way Banding	7
2.3 Method 3 – 4-way Banding Overpack	8
3.0 General Palletization Guidelines	10
3.1 Partial Pallet Loads	10
4.0 Pallets	11
5.0 Minimum Material Specifications	12

1.0 Introduction

1.1 Abstract

Lenovo requires the usage of a specific pallet unitization methodology to properly secure product. Due to different material availability, equipment capabilities, and the broad scope of this document there are multiple acceptable approaches to proper Lenovo product unitization.

1.2 Purpose

- To establish parameters for pallet unitization for all Lenovo and customer assets.
- To eliminate the use of unsafe, inefficient, & counterproductive pallet unitization methods.
- To eliminate all inconsistencies by limiting choices for pallet unitization.
- To standardize on packaging palletization elements providing visual indicators and allowing development of training programs to ensure compliance.

1.3 Compliance

Compliance with the requirements herein will be enforced as a condition of purchase per Lenovo purchase contracts. No deviations are to be made without written approval from Corporate Packaging and Asset Protection (when applicable). Auditing will take place at Lenovo's discretion.

1.4 Scope

This specification details the correct methods used to prepare pallet loads for shipment to or from Lenovo, distribution warehouses, dealers, business partners, and customers.

2.0 Acceptable Unitization & Securement Methods

This section illustrates and explains the Best of Breed unitization & securement methods approved by Lenovo. These methods must be used in the securement of loads regardless of pallet size. Best of Breed palletization applies to full, half and unique sized pallet loads. Method 1 is the preferred technique. In the absence of roping capabilities, methods 2 & 3 are acceptable.

2.1 Method 1 – Roping Technique & 2-way Banding

This method requires the use of a programmable automated stretch wrapper with the ability to “rope.” This is the preferred method of unitizing loads.

Figure 1.

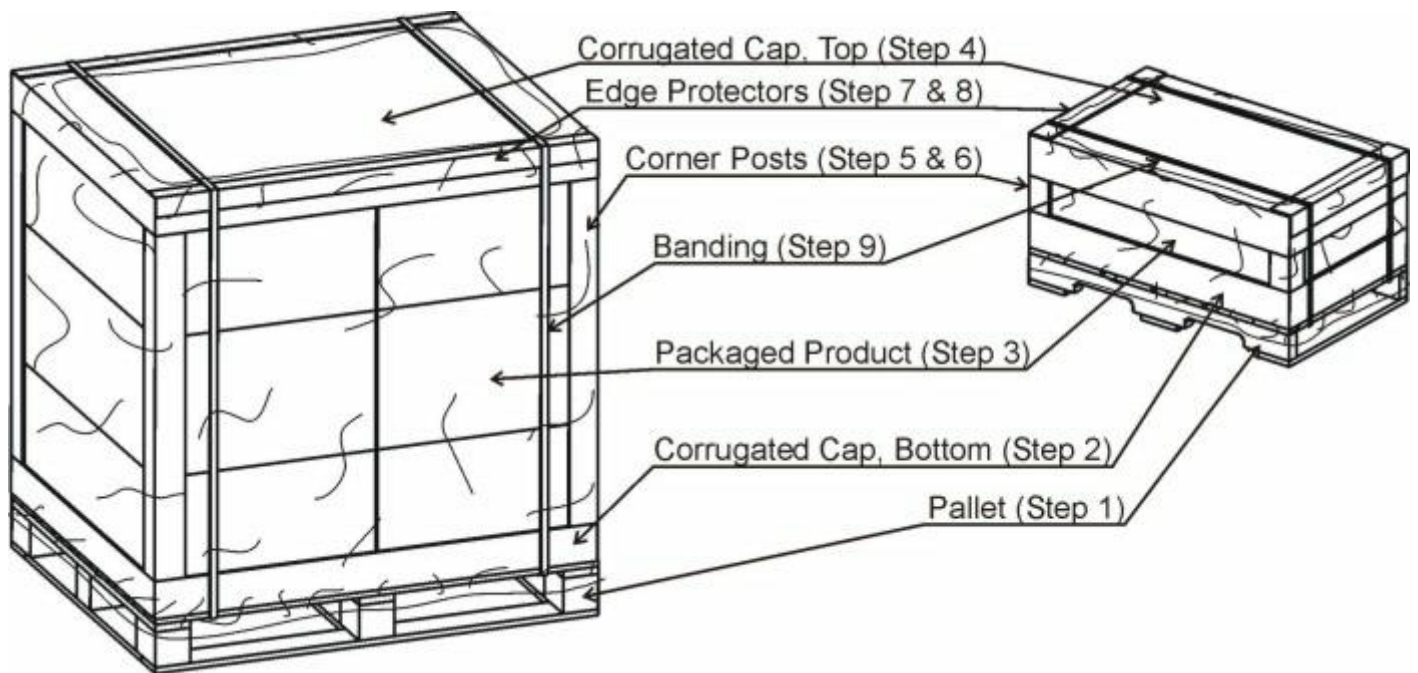

2.1.1 Required Materials:

QUANTITY	DESCRIPTION
1	Pallet
2	Corrugated Cap
4	Vertical Corner Posts
2	Edge Protectors
2	Banding
2	Banding Clip
2	Pallet Labels
-	Stretch-Wrap

2.1.2 Instructions for Assembly

1. Select appropriate pallet for load size as instructed by the product's packaging procedure.
2. Place corrugated cap on pallet.
3. Load the packaged products into the corrugated cap as instructed by the product's packaging procedure.
4. When the palletized load is complete, place a corrugated cap over the top of the cartons.
5. Select appropriate corner post or cut corner posts to the correct length. Corner posts must measure from the top of the pallet to the top edge of the palletized load.
6. Place the vertical corner posts between the corrugated caps and the system cartons.
7. Select appropriate top edge protector or cut protectors to the correct length. Top edge protectors must measure from the left to the right edge of the top corrugated cap.
8. Place the top edge protectors on the outside edge of the top cap as shown in figure 1. It may be necessary to use tape to hold the edge protectors in place.
9. Apply two-way banding as shown in figure 1.
10. Using a programmable stretch wrapping machine, wrap the load using roping. The program for the wrapper must wrap a minimum of three times around the base and four times around the top of the load with 100% coverage of product. If roping capabilities are not available, you must use Methods 2 or 3.

2.1.3 Roping Technique

Figure 2.

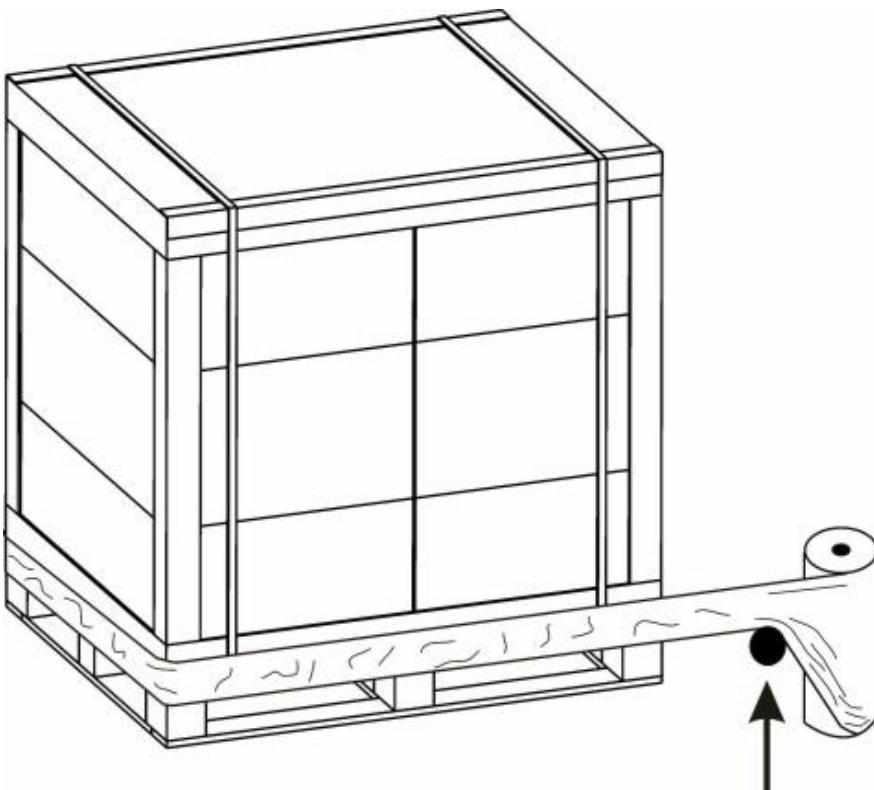

“Roping” is a method in which a device is used to gather the stretch-wrap into a rope-like bundle while the film is being stretched around the entire pallet load. The “roped” film **MUST** securely grab the pallet tightly to keep the pallet contents from shifting during shipment.

2.2 Method 2 – Hand Stretch-wrapping and 4-way Banding

Figure 3.

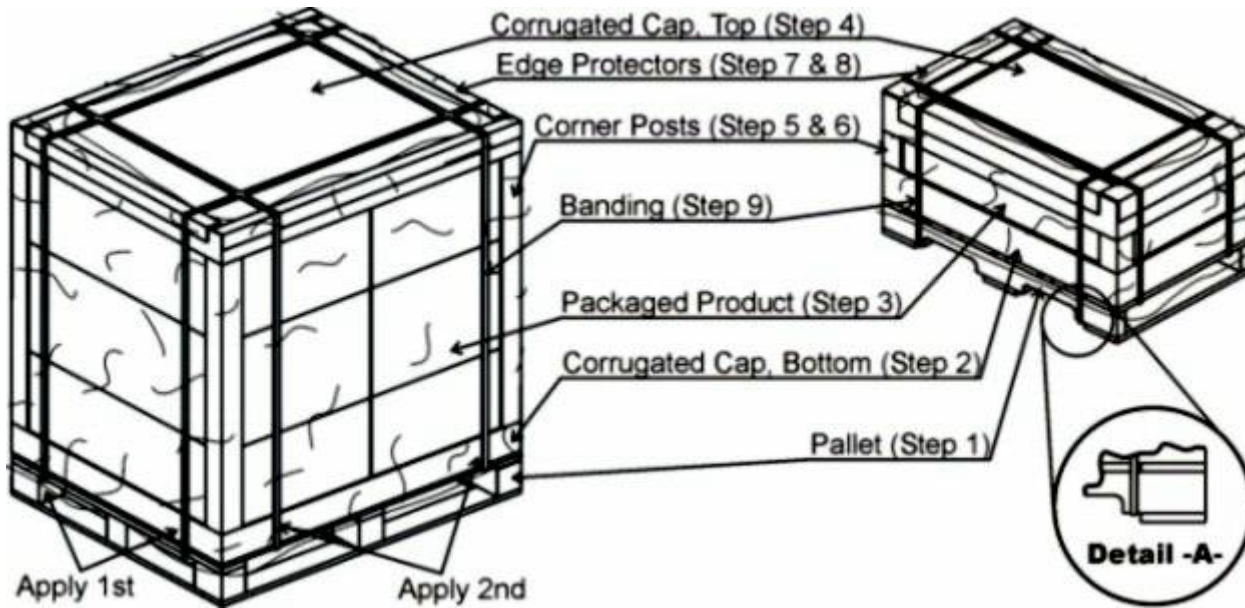

2.2.1 Required Materials

QUANTITY	DESCRIPTION
1	Pallet
2	Corrugated Cap
4	Vertical Corner Posts
4	Edge Protectors
2	Banding
2	Banding Clip
2	Pallet Labels
-	Stretch-Wrap

2.2.2 Instructions for Assembly:

1. Select appropriate pallet for load size as instructed by the product’s packaging procedure.
2. Place corrugated cap on pallet.
3. Load the packaged systems/cartons into the corrugated cap as instructed by the product’s packaging procedure.
4. When the palletized load is complete, place a corrugated cap over the top of the cartons.
5. Select appropriate corner post or cut corner posts to the correct length. Corner posts must measure from the top of the pallet to the top edge of the palletized load.
6. Place the vertical corner posts between the corrugated caps and the system cartons.
7. Select appropriate top edge protector or cut protectors to the correct length. Top edge protectors must measure from the left to the right edge of the top corrugated cap.

8. Place the top edge protectors on the outside edge of the top cap as shown in figure 3. It may be necessary to use tape to hold the edge protectors in place.
9. Apply four-way banding. For block style pallets, apply bands to short side of pallet first. For stringer style pallets, route band correctly using notch (see detail -A- in figure 3).
10. Apply stretch-wrap to the palletized load. Wrap around the base of the load and pallet at least three times to help secure the load to the pallet. Cover 100% of product with stretch-wrap to prevent damage to cartons.

2.3 Method 3 – 4-way Banding Overpack

Figure 4.

2.3.1 Required Materials

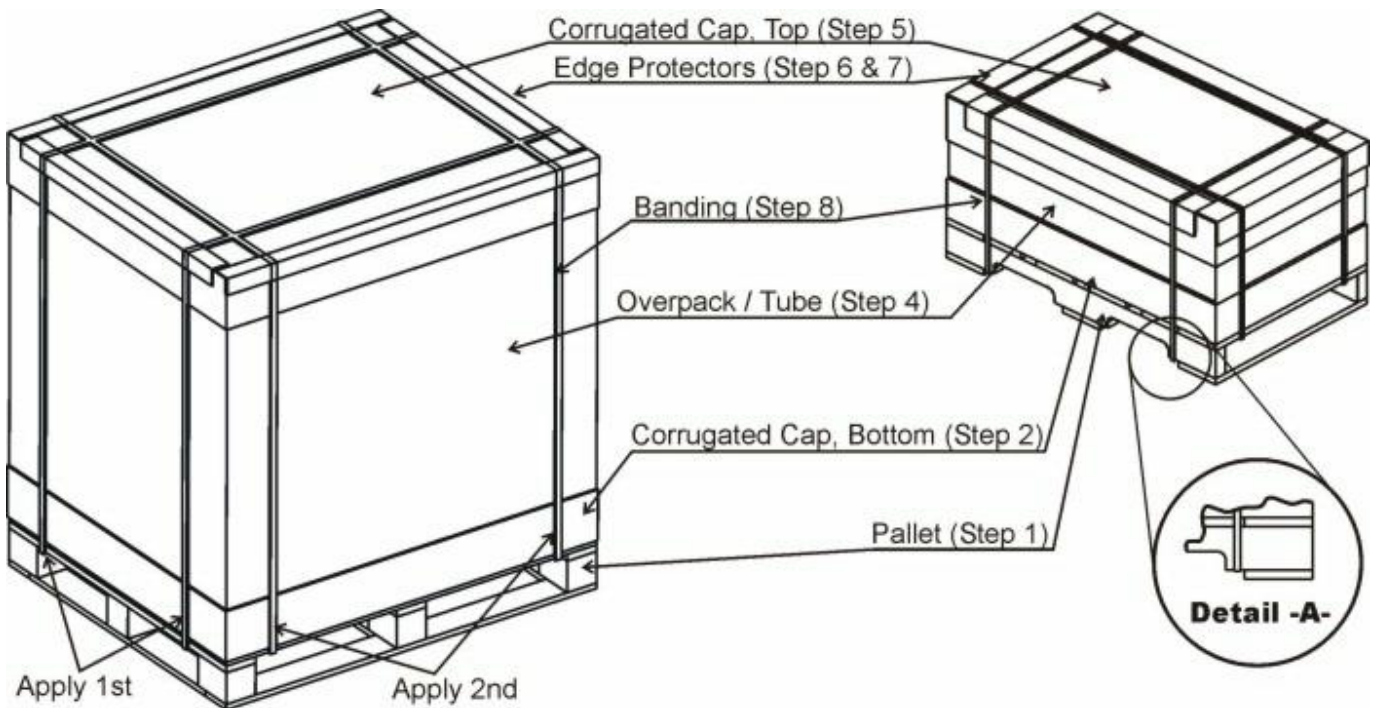

QUANTITY	DESCRIPTION
1	Pallet
2	Corrugated Cap
1	Sleeve (Tube)
4	Edge Protectors
4	Banding
4	Banding Clip
2	Pallet Labels

2.3.2 Instructions for Assembly

1. Select appropriate pallet for load size as instructed by the product's packaging procedure.
2. Place corrugated cap on pallet.
3. Load the packaged systems/cartons into the corrugated cap as instructed by the product's packaging procedure.
4. Place overpack (tube) over product, inside the bottom cap.
5. Place a corrugated cap over the top of the load.
6. Select appropriate top edge protector or cut protectors to the correct length. Top edge protectors must measure from the left to the right edge of the top corrugated cap.
7. Place the top edge protectors on the outside edge of the top cap as shown in figure 4. It may be necessary to use tape to hold the edge protectors in place.
8. Apply four-way banding. For block style pallets, apply bands to short side of pallet first. For stringer style pallets, route band correctly using notch (see detail -A- in figure 4).

3.0 General Palletization Guidelines

- Leaning, staggering, bulging, unstable, and/or overhanging loads are unacceptable. The bottom layer should contain the heavier parts.
- The top and bottom surfaces of palletized loads must be flat to permit stacking.
- Parts/unit packages must be kept clean. Wrapping or overpacking the unit loads is required for protection from dirt, dust, etc.
- All palletized loads must be fully secured to the pallet using banding and/or stretch wrap.
- Overhang of boxes on the pallet deck is not acceptable.

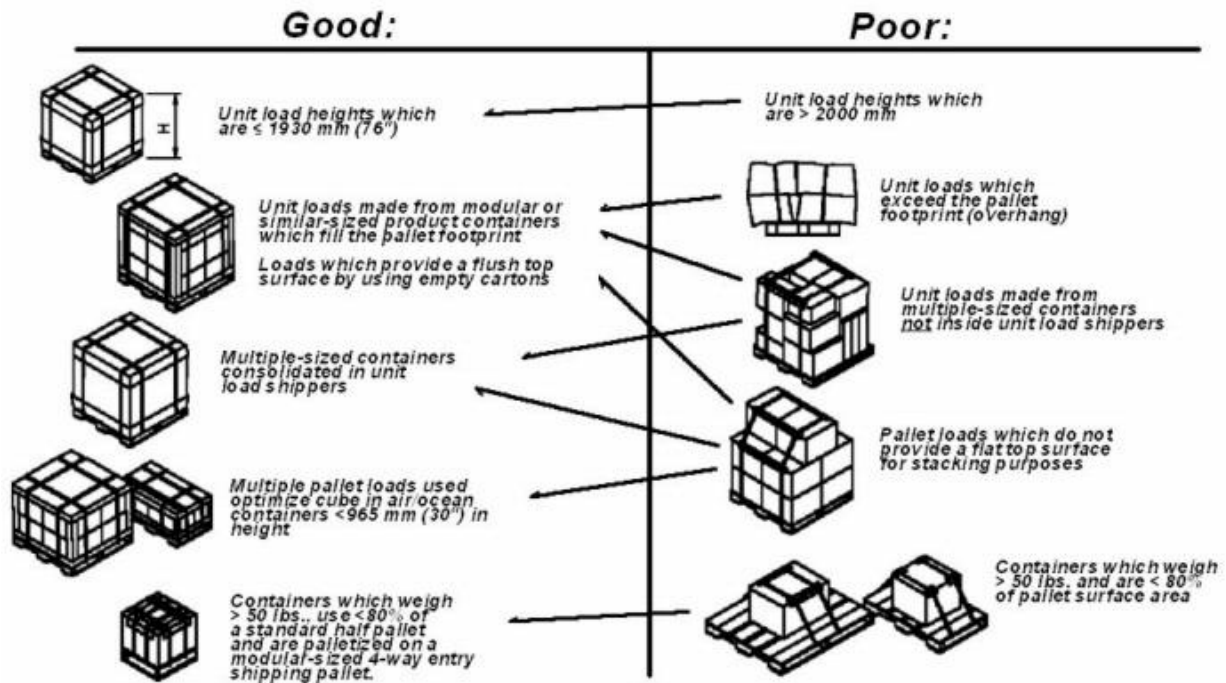

3.1 Partial Pallet Loads

Order quantities or configurations may result in less than full or partial pallet loads.

- Use empty cartons to fill out the load. Be sure the cartons are clearly marked "empty carton".
- Load must produce a flat top surface. Size the load to the pallet as instructed by the product's packaging procedure. Use Lenovo full or half pallets that best fit the load.

4.0 Pallets

A summary listing of acceptable pallet choices is provided below. Refer to the product bill of materials and product packaging instructions for specific requirements and materials for palletization loads.

Pallet Type		Size(mm)	Weight(kg)	Material
EUR Pallet (EPAL)		1200 x 800 x 135	15	Solid wood
GMA Pallet		1219 x 1016 x 120	22	
Low-profile Pallet	General Size	1200 x 1000 x 112	14	Plywood
	EUR Size	1200 x 800 x 112	14	
Ultra-light Pallet	General Size	1200 x 1000 x 112	9.8	
	EUR Size	1200 x 800 x 112	8.5	

Lenovo strongly recommends the application of standard size pallet in the industry and tries to eliminate the use of non-standard size pallet in Lenovo packaging. The well-recognized standard pallets are as shown above. Lenovo claims to apply the ultra-light pallet to the air shipment.

Due to the consideration of pest free and export restriction, the 1st material selection on pallet is plywood. Please follow the requirement from ISPM-15 and all manufactured wood packaging (MWPM) must be marked regardless of origin or destination. MWPM becomes immune to infestation as it is created and therefore does not require secondary treatments.

The solid wood (NMWP or SWPM) pallet is only selected as the domestic shipment and special customized request (i.e. GMA). The IPPC edict, known as ISPM 15, gives solid wood packaging manufacturers the option of heat treatment, requiring that the solid wood core temperature reaches a minimum of 56 degrees Centigrade (133 F), for min. 30 minutes. All ISPM 15 compliant wood is then stamped with an approved mark signifying that it meets the ISPM 15 standards.

- Prohibited Treatments: Chemical Fumigation is not allowed for packaging purposes.

All the pallets used for lenovo packaged products shipment must pass the relative test per EIPS 2003 (ASTM D1185). The brief test requirement is as followed.

- Static loading: 1,800 kg
- Conveyor loading: 500 kg
- Racking: the max deformation is 6 mm in height.
- Corner drop test: 12 drops at 1m and max. deformation of 1.5%

5.0 Minimum Palletization Material Specifications

- Pallet caps - 200 psi/ECT 32 PSI double wall corrugated
- Corner Posts - Fiberboard, 5mm thickness/50mm x 50mm wide
- Sleeve - 275 psi/ECT 48 Single or double wall corrugated
- Stretch-wrap – 0.02 thickness LLDPE film
- Banding - Plastic only (polyester) -15mm wide/1.0 thickness

---End of Document---